



# Technical Information

## Surface temperatures of fabric expansion joints

RAL-GZ 719

TI-016

Rev. 1

Page 1 of 2

### 1. General

There is a limitation to influence the heat transfer from the medium to the fabric expansion joint system because of functional requirements. Therefore on components like expansion joint bellow, duct flange, fastening parts higher temperatures can be expected than on adjacent components. At medium temperatures higher than 300 °C (570 °F) the surface temperature on the outside of the expansion joint system will possibly be higher than 60 °C (140 °F).

### 2. Surface temperatures

The below mentioned tables show the possible temperature values at ambient temperature of maximum 50 °C (120 °F).

#### 2.1. Flanged expansion joints

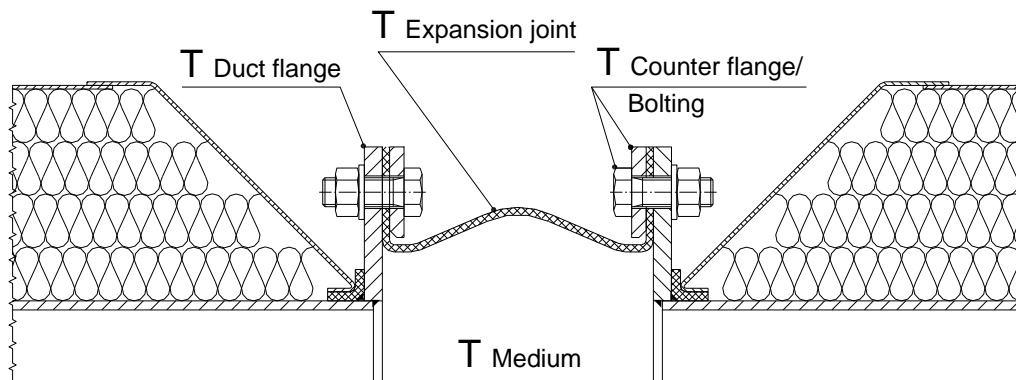

T Medium	T Duct flange	T Counter flange/ Bolting	T Expansion joint
200 °C (390 °F)	200 °C (390 °F)	120 °C (250 °F)	150 °C (300 °F)
300 °C (570 °F)	300 °C (570 °F)	150 °C (300 °F)	200 °C* (390 °F)
400 °C (750 °F)	400 °C (750 °F)	180 °C (355 °F)	≤ 250 °C (480°F)

\* Depending on the expansion joint design temperatures up to 250 °C (480 °F) can be reached.

**Edited by the Quality Committee of the Quality Association for Fabric Expansion Joints**

### 2.2. Belt expansion joints (e.g. with pre-insulation)

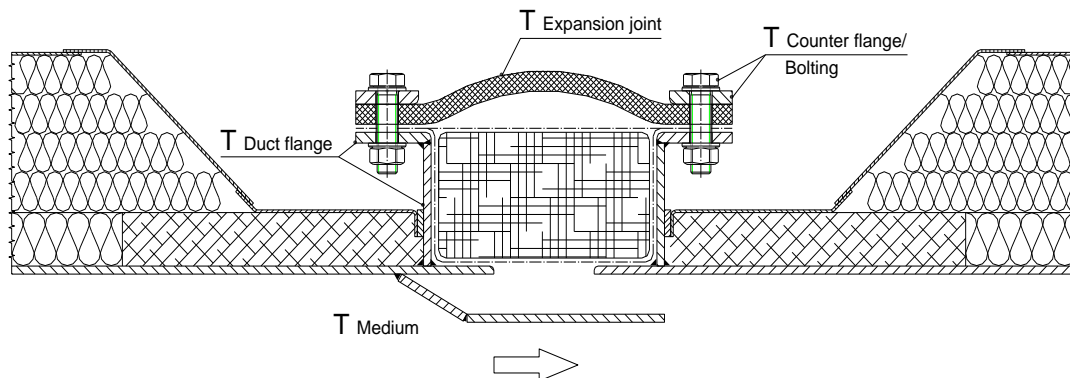

T Medium	T Duct flange	T Counter flange/ Bolting	T Expansion joint
300 °C (570 °F)	250 °C (480°F)	120 °C (250 °F)	150 °C* (300 °F)
400 °C (750 °F)	300 °C (570 °F)	150 °C (300 °F)	200 °C* (390 °F)
500 °C (930 °F)	320 °C (610 °F)	180 °C (355 °F)	≤ 250 °C (480 °F)
600 °C (1110 °F)	350 °C (660 °F)	200 °C (390 °F)	≤ 250 °C (480 °F)
700 °C (1290 °F)	380 °C (715 °F)	220 °C (430 °F)	≤ 250 °C (480 °F)

\* Depending on the expansion joint design temperatures up to 250 °C (480 °F) can be reached.

It has to be kept in mind that secondary influences e.g. radiation or lacking convection can affect these values considerably.

### 3. Safety measures

The surface of the expansion joint bellow has considerable lower heat conductivity than the metallic components. The result of this is an appropriate reduced risk potential. In general a direct risk can be excluded when touching the expansion joint bellow.

At platforms or running boards there could be a risk for persons touching the metallic parts like duct flange and fastening parts. In this case a personnel guard has to be installed by others. An adequate convection has generally to be ensured (see TI-011 item 2.).

A possible outside cover or insulation as personnel guard may damage the expansion joint and is therefore not suitable as a safety measure.

**Edited by the Quality Committee of the Quality  
Association for Fabric Expansion Joints**